



FPL

An ideal solution for uniform sign or facade illumination.



“UNIQUE LIGHTING SOLUTIONS”

ORDERING

FPL-(watt)	(watt) = specified Wattage
-MH	150W Metal halide lamp
-HPS	High Pressure Sodium
-CRI	Color Rendering Index*
-CCT	Color Correlated Temperature*
-ELEC	Electronic Ballast
-TF	Cast Metal Tenon Fitter
-CF	Custom Finish*
-XXX	Ballast Voltage*
-AGS	Anti Glare Shield (internal)
-CL	Colored Lens*
-SPG	Special Glass Pattern*
-FLP	Facade Lighting Package
-SNXX	Snoot in inches (note internal color)*
-PR	Polished Reflector

* Consult Factory

DIMENSIONS

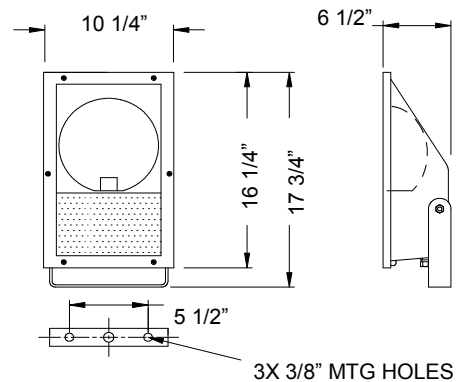

PHOTOMETRICS

EXAMPLE: FPL-150-MH-85-3000-CWA-120

*Photometrics
Coming Soon*

SPECIFICATIONS

Housing– High grade, cast aluminum with cast lens frame for complete seal against moisture.

Lamps– 150W Metal halide or 50W to 70W high pressure sodium lamp. Please contact factory for lamp selections not found on ordering selector.

Lens– Clear tempered glass lens.

Reflector– High quality 3002 aluminum, hydro-formed for maximum lumen output while maintaining a high degree of uniformity.

Finish– High quality, outdoor, polyester, powder coat.

Electrical– Integral Core and coil ballast. Electronic ballasts are also available.

Mounting– The mounting is a formed steel yoke. Provided with degree indicators for easy positioning.

Weight– Approximately 16 lbs (with no options).

Labels– NRTL Listed for wet locations.